

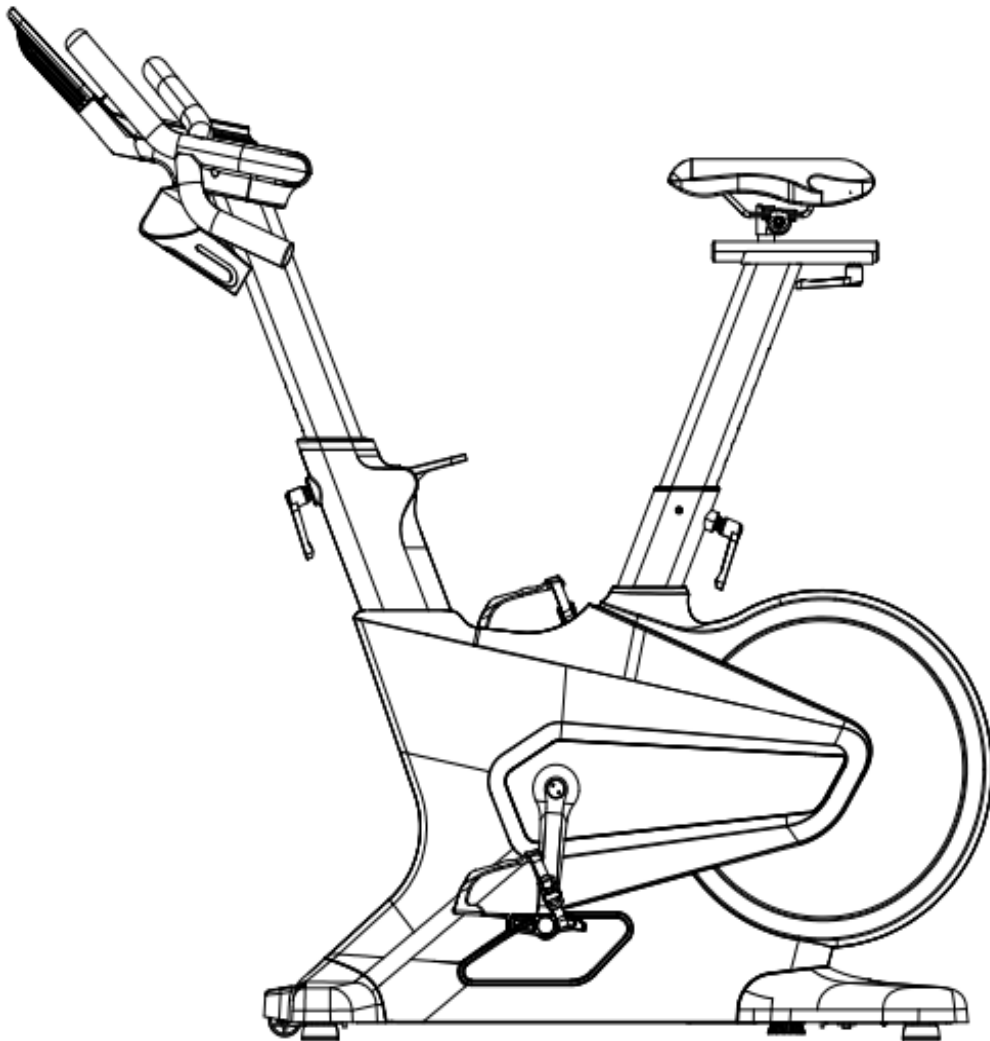

FRENCH FITNESS

FF-MIC20

Product instruction Manual



contents

Safety instructions	01
Daily maintenance	02
Product introduce	03
Parts list	04
Installation Instructions	05
Use adjustmentinstruction	10
Instructions of the electronic watch	17
Dowload the APP	18
instructions	20
Start guide	

Safety instructions

(Please read carefully that the irregular use may lead to personal injury!)

1. Make sure that the cushion height adjustment knob is fixed properly, and does not interfere with the range of movement during movement.
2. Please keep the children and pets away from the product.
3. Do not extend any objects or body parts into any opening of the bike.
4. The weight of the user shall not exceed the maximum weight bearing.
5. Must wait for the flywheel and foot pedal to stop turning if not comply may lead to loss of control and serious injury.
6. If you feel any uncomfortable such as dizziness or breathing difficulties, please gradually stop stepping on it and get off carefully.
7. Do not turn the foot pedal by hand and not touch any rotating machinery that may cause physical damage.
8. Keep your body hydrated throughout the ride as needed.
9. Please use the equipment as indicated in the instructions, warm up well before you exercise
10. Do not exercise at a higher speed and intensity without a preliminary determination of the baseline fitness level and a doctor. Notice body state, posture and establish controllable speed before trying any high-intensity short sprint.
11. Please wear professional cycling clothes or tight sportswear, and wear sports shoes, pull tight foot cover to avoid being pulled by the equipment, involved in sports injuries
12. Do not use products without suitable shoes. Do not use products barefoot.
13. Incorrect or excessive training may cause injury.
14. Please check the bike is loose or damaged before each use.
15. Do not modify the vehicle or use non-original accessories, do not open the casing to avoid damage to the equipment.
16. Patients with hypertension and heart disease, lumbar disease, pregnant women, mobility difficulties, please obtain the doctor's consent.
17. If you feel dizziness or chest pain during the exercise, please stop exercising immediately and go to the hospital for examination.
18. Stop using it immediately when the product is broken.
19. This product is not used for medical rehabilitation purposes.
20. Please use the product on a flat, clean ground.
21. Please perform regular preventive maintenance.
22. Do not expose product in wet environment This product is not suitable for outdoor use or in any wet environment.
23. The product is designed for household non-medical fitness devices, with a maximum load of 150kg.
24. During exercise, the inertia wheel and foot pedal stop turning before getting off or if emergency braking is not observed, it may lose control and get hurt.
25. Turn the component knob to the right to tighten to lock the corresponding device component.
26. When using the bicycle screen bracket, the equipment needs to be placed in the center to prevent the device from falling off.
27. The foot must be put into the foot rubber sleeve, tighten the bandage to avoid the danger caused by the foot pedal.

Daily maintenance

1. Spinning bikes should be placed on a dry, ventilated, flat ground. If not use for a long time, need to cover the car cover, to keep the machine clean and tidy
2. After exercise, dry the sweat on the frame. Do not wipe with a wet cloth to avoid rust.
3. Check whether the belt plate is cracked or deviated, adjust or replace the belt in time; clean the belt groove regularly to prevent the belt from jumping move the slot.
4. Check frequently whether the screws in all parts of the car body are loose or fall off, and they should be tightened or replaced in time.
5. Check frequently whether the resistance knob is loose or falls off, and whether the resistance value is reasonable, so as to calibrate the resistance value in time.
6. Check frequently whether the screws between the foot and the crank are loose and tighten them in time.
7. Check frequently whether the cushion is loose and should be tightened in time. Please wipe the pad with cotton cloth to keep the pad dry.
8. For the long-term use of this product, please wipe dirt regularly. At the same time, please do not directly water or wipe with gasoline, grinding powder. Otherwise it may cause cracks, electric shock or fire in parts or bodies, use a dilute neutral detergent for maintenance

Reminder
Ask your physician before starting any exercise. This is particularly important for individuals over 35 or with preexisting health problems. Read all the instructions before using any device.

Product introduce

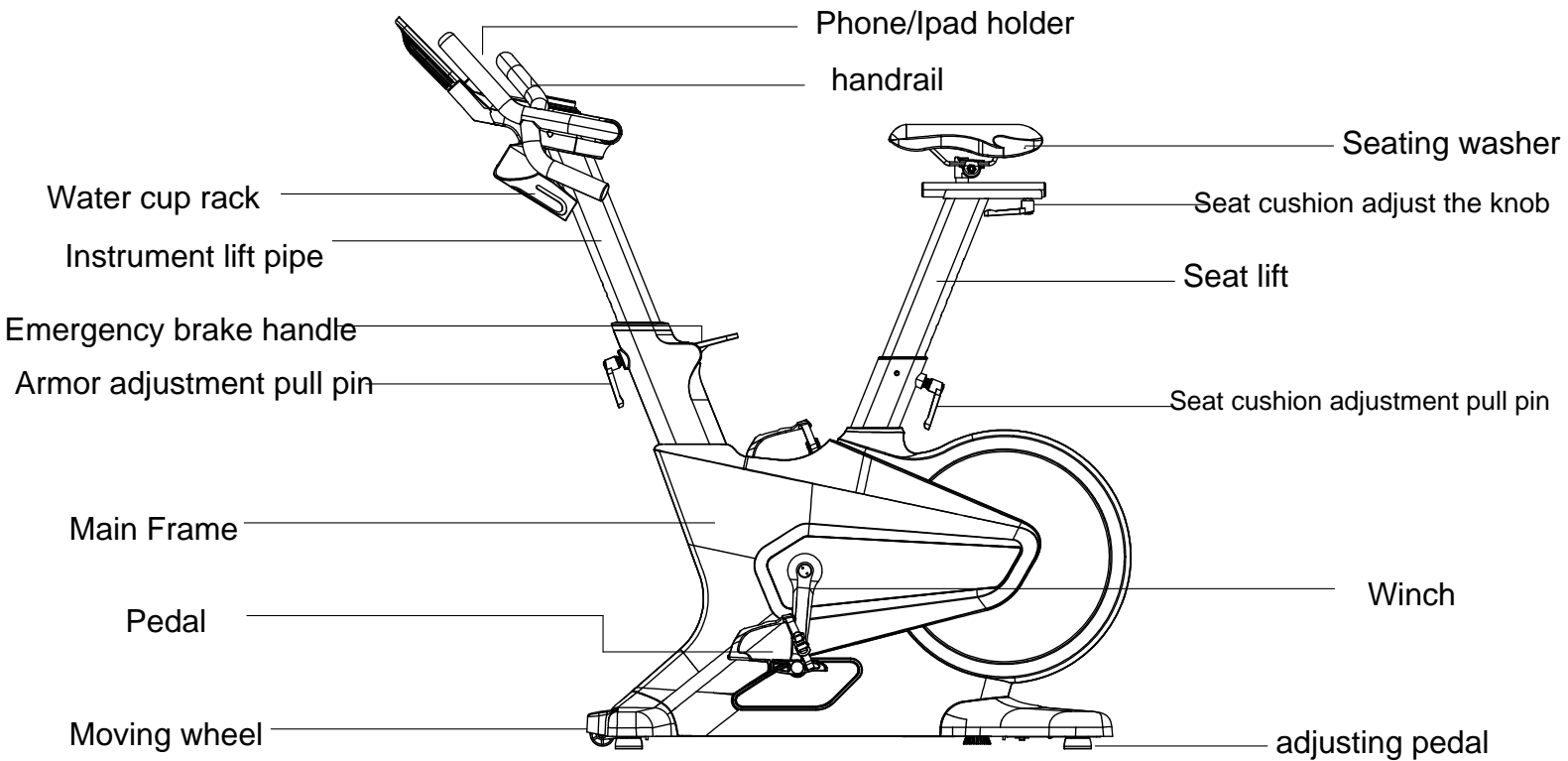

Product model : FF-MIC20

Product Size : 1310*535*1295mm

Product N.W : 60 kg

Product G.W : 67 kg

Parts list

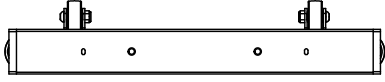
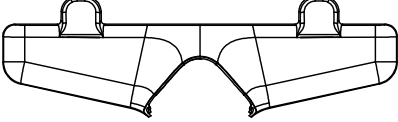
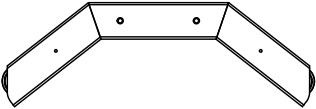
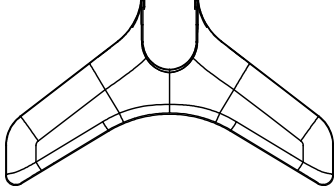
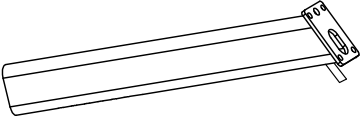
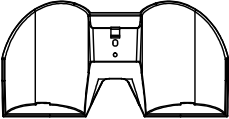
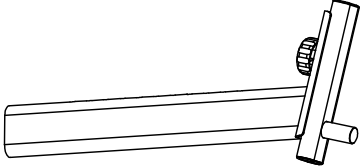
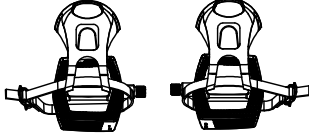
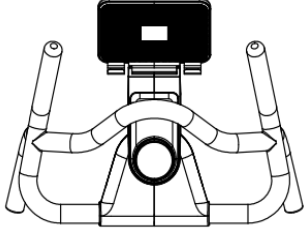
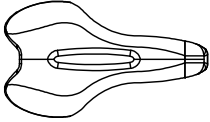
<p>A.the forefoot tube</p>	<p>B Front foot cover</p>
	
<p>C.the rearfoot tube</p>	<p>D.Back foot cover</p>
	
<p>E.Instrument lift pipe</p>	<p>F. Water cup rack</p>
	
<p>G.Seating lift adjust tube</p>	<p>P. pedal</p>
	
<p>H Armor assembly</p>	<p>Z the seating</p>
	

Installation Instructions

Forefoot tube installation:

Find the front foot pipe A and B in the package, remove the 10 * 40 of the front foot, lock the front foot pipe A through the main frame, and then tilt the front foot cover cover of B on the front foot pipe of A with 24.2 * 35 self-tapping screws through the front foot to secure the front foot cover B.

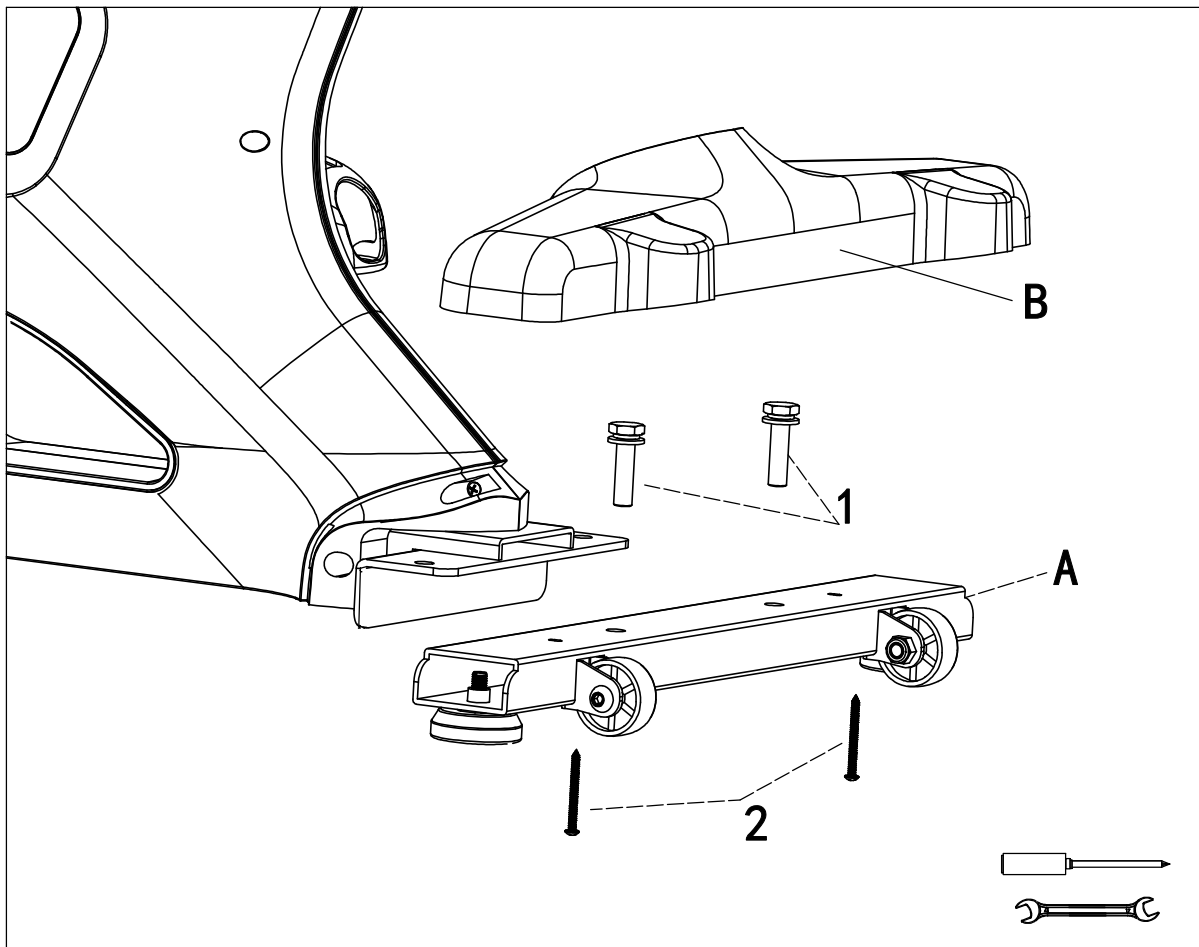

Installation Instructions

Rear foot tube installation:

Find the C rear foot and D rear foot cover in the packaging, remove the two 10 * 45 of the rear foot, then remove the 10 * 80 of the rear foot, lock the C back foot through the main frame, and then tilt the machine with two 4.2 * 35 self-tapping screws through the front foot to lock the D rear foot cover.

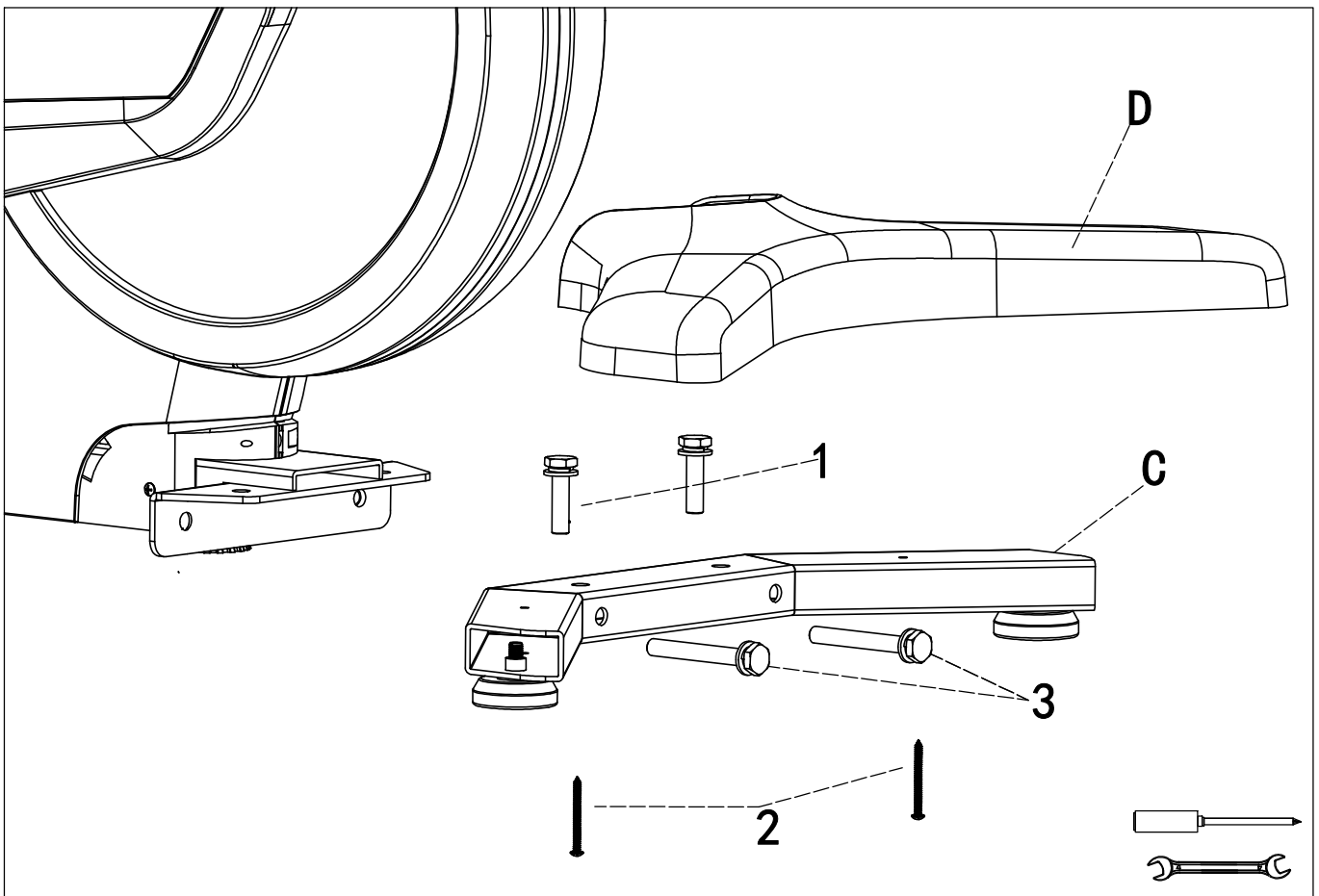

Installation Instructions

Adjust tube installation:

Find the E instrument pipe, then pass the main signal line through the instrument pipe , pull out the front armrest adjustment pin and plug the E instrument tube into the front fixing pipe of the main frame. Find the G cushion lifting tube, pull out the adjusting pin and insert the G cushion tube into the rear pipe after the main frame. Attach the Z cushion to the cushion tube with a 13 # wrench

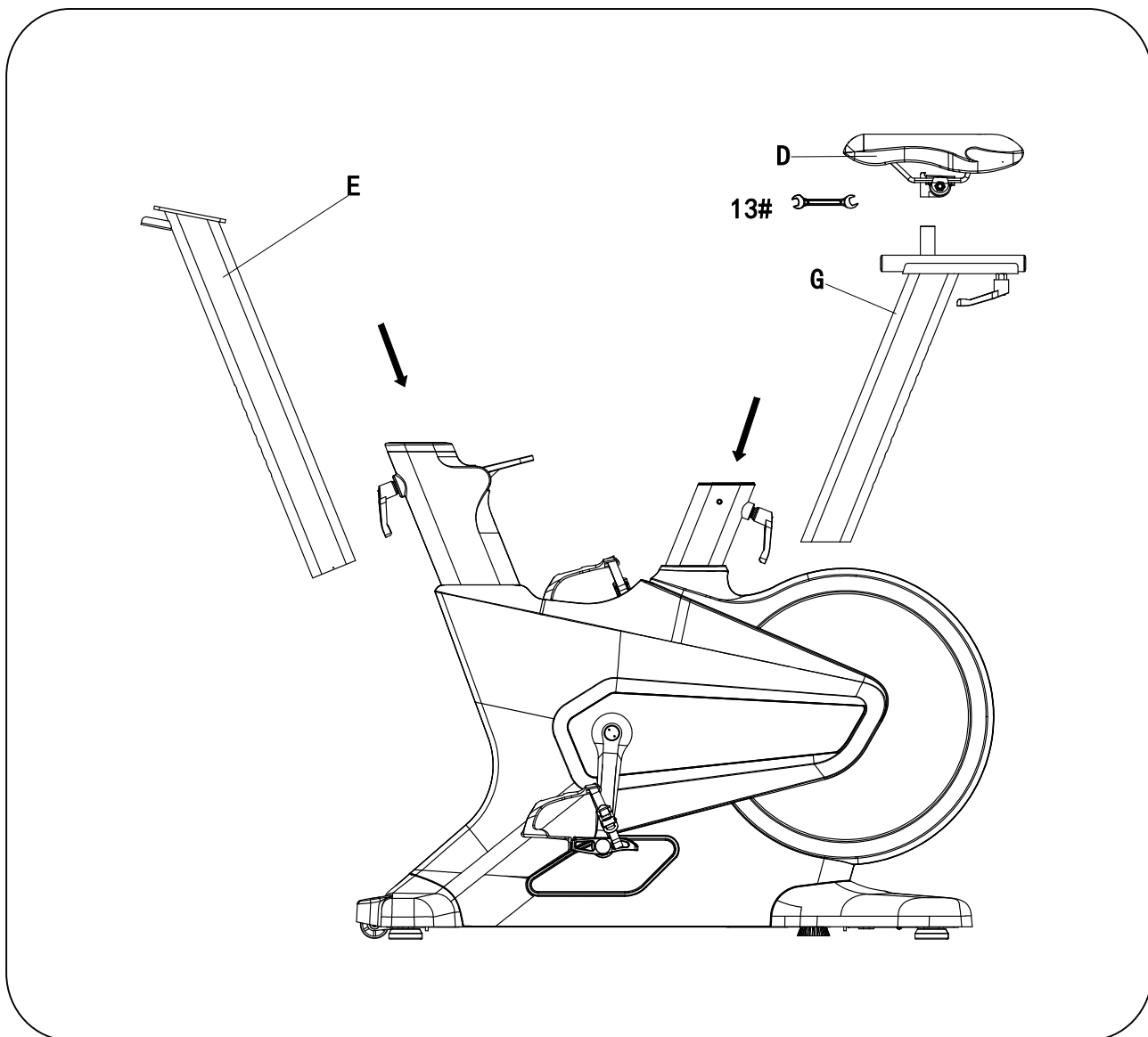

Installation Instructions

Install the armrest

1. Find the H handrail assembly, connect the main signal line of E instrument pipe docking B armrest assembly of the table (please pay attention to the pin is not skew, gently buckle, not too hard to damage the pin), find 4 half head socket bolt 4 M8 * 12 through E instrument pipe lock H armrest assembly, find the 5 # socket wrench lock bolt
2. Find the F water cup holder, lock the 5 inner hexagon bolts M6 * 12 and 6 flat pads 6 * 16 on the H armrest assembly, lock it on the H armrest assembly, and lock it with the 5 # inner hexagon wrench

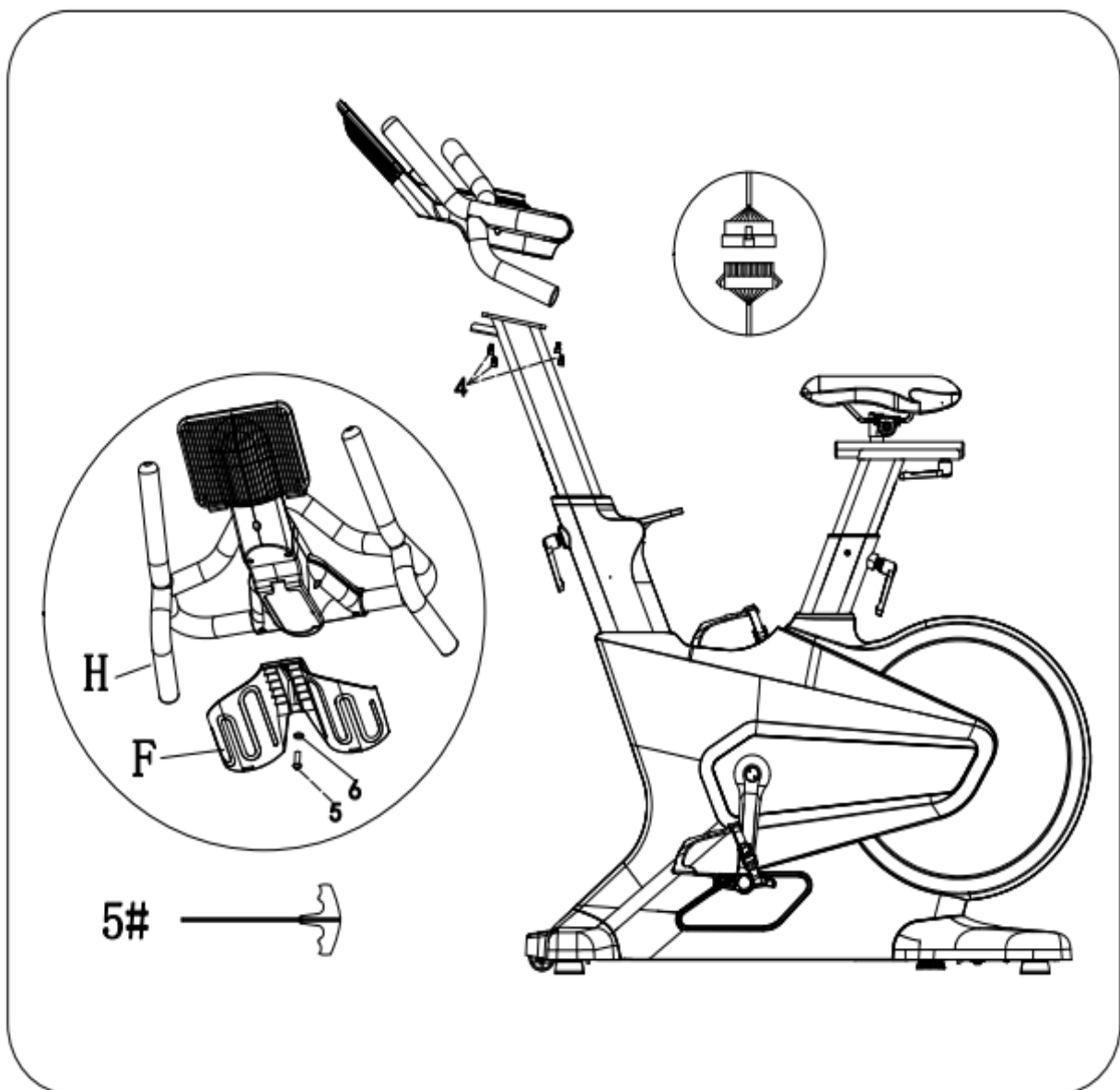

Installation Instructions

Pedal installation:

Find the P pedal L \ R, rotate the pedal L with the main frame L counter-clockwise, rotate the pre-load clockwise, and lock the pedal with a 15 # wrench

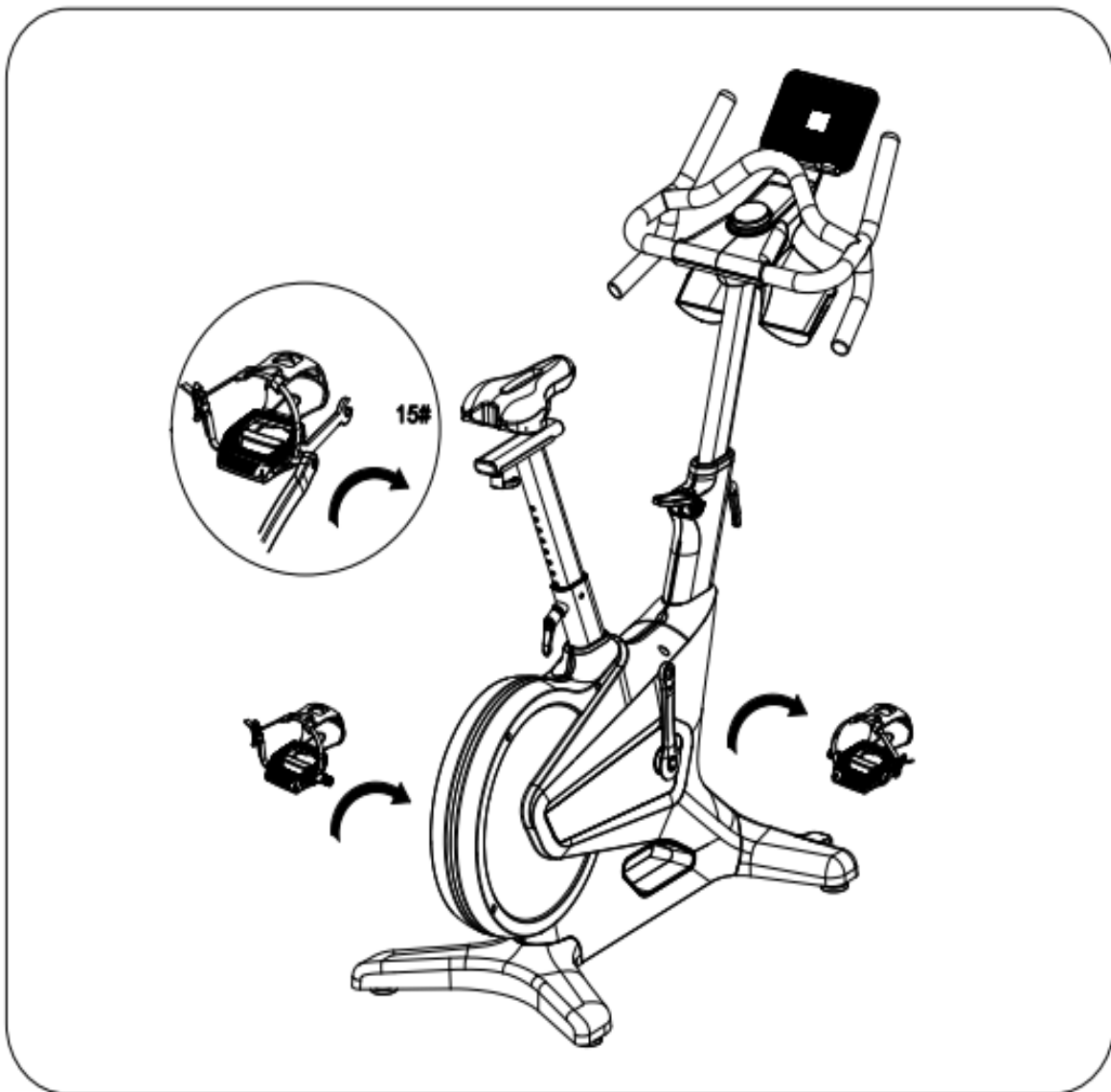

Use adjustment instructions

How to find the right cycling posture

1. Seat height

Keep your feet together, stand straight on the side of the owner's frame, adjust the cushion to the same height as the hip joint (Figure 1), then sit on the seat cushion, pedal with the heel, stop it at 6 o'clock, and the legs can be fully straight (Figure 2)

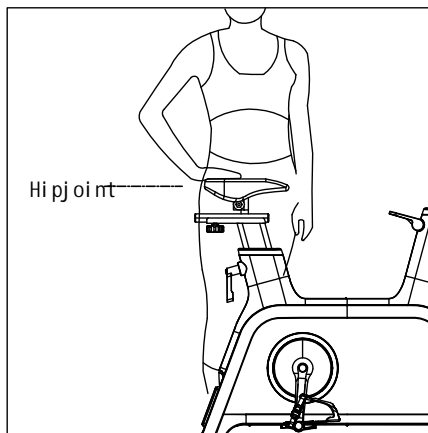

(Figure 1)

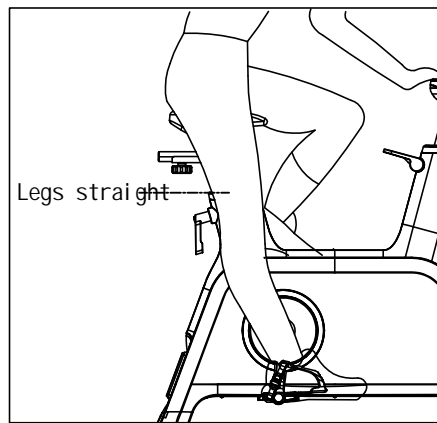

(Figure 2)

2. Front and rear position of seat cushion

Put the right foot shoe into the set, step on the pedal, stop it in the direction of 3 o'clock, let the front side of the knee joint and the foot pedal on a vertical line, which is the correct position (Figure 3)

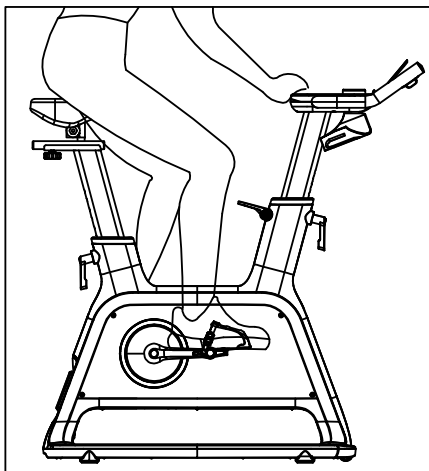
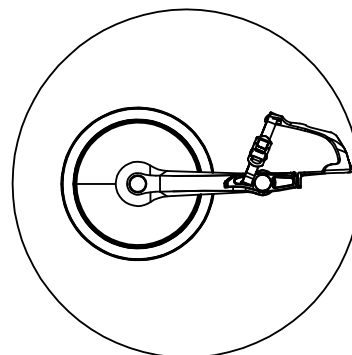

Figure3



Use adjustment instructions

3. Set the appropriate armrest height

Each user can set the appropriate handrail height according to their own height and cycling experience.

We suggest: novice users (Figure 4), armrest height slightly higher seat cushion, experienced users (Figure 5) armrest height and seat cushion, parallel to or slightly below the seat cushion. For users with lumbar muscle strain and lumbar spine disease, it is recommended to adjust the handrail to a higher position when riding with the consent of the doctor.

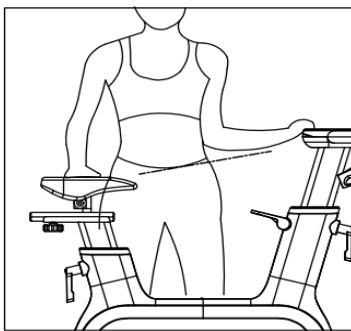

Figure 4

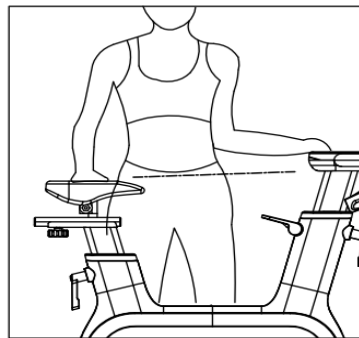
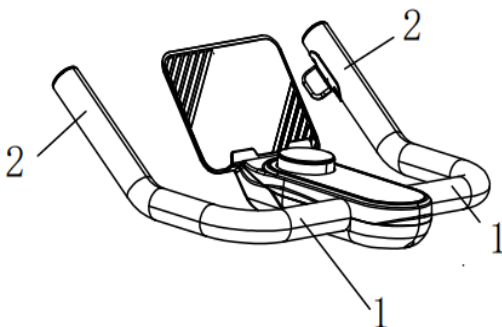

Figure 5

4. The handle

During cycling, the coach will indicate the corresponding handle position, that is, the appropriate position of the handrail, as shown in the figure:



- 1 The first seat
- 2 The second seat

Use adjustment instructions

5. Seat Angle adjustment

Use the 13 # open wrench to slightly rotate the nuts on both sides of the bottom of the cushion (Figure 6), press the cushion head down with hand, and adjust to a more comfortable Angle. (it is recommended to adjust to the cushion head down one case) and lock the left and right nuts of the bottom.

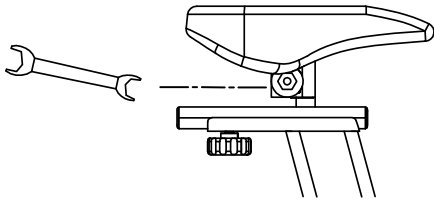

Figure 6

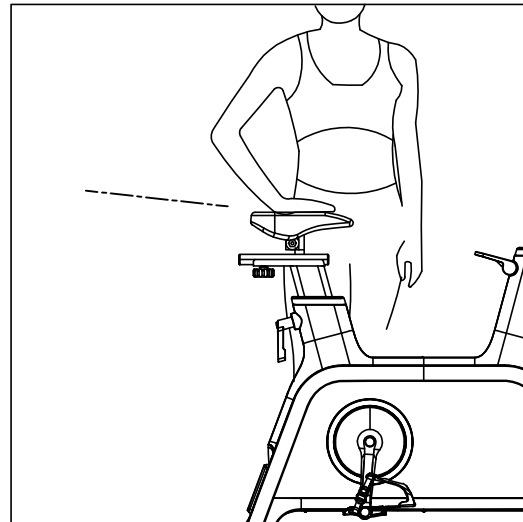

Figure 7

Suggestion: If the buttocks are slightly uncomfortable during riding, you can adjust the seat cushion down.

Use adjustment instructions

The adjustment method of the seat cushion

6. Adjust the cushion before and after

Turn the knob in the direction 1-2 laps, you can move the cushion back and forth, and then fix it in a position suitable for your own use Lock the knob in the right direction.

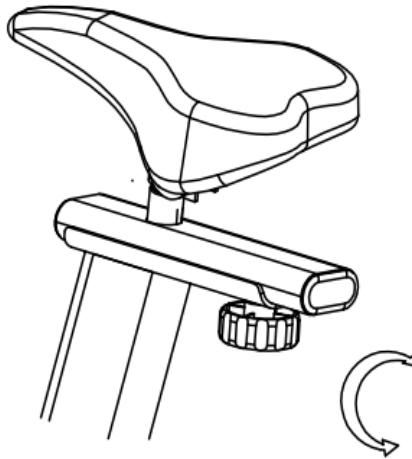

7. Emergency brake bars used

Press the STOP red emergency brake with one hand down below put, the bicycle flywheel will stop running to drive, loose the rear emergency brake handle will be built-in spring force kick-back.

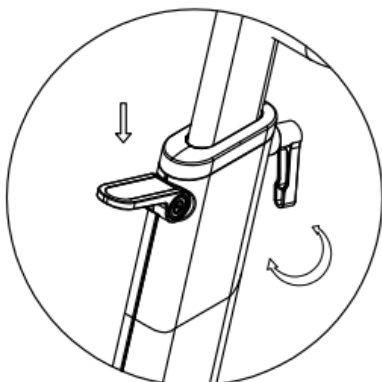

8. Bicycle level adjustment instructions

If the bike shakes slightly during use, please adjust the four foot pads under the front and rear horizontal pipes, and adjust the elevation or lower after rotation to keep the bike horizontally.



Use adjustment instructions

9. Adjust about the handrail height

As shown in the figure, rotate the L-shaped pull pin counterclockwise and loosen the 2-3 figure. Then pull the pin out with one hand, and then move the armrest instrument up and down with the other hand. Tube, you can adjust up and down the comfortable height suitable for their own movement. After fixing, lock and hold the pull pin clockwise.

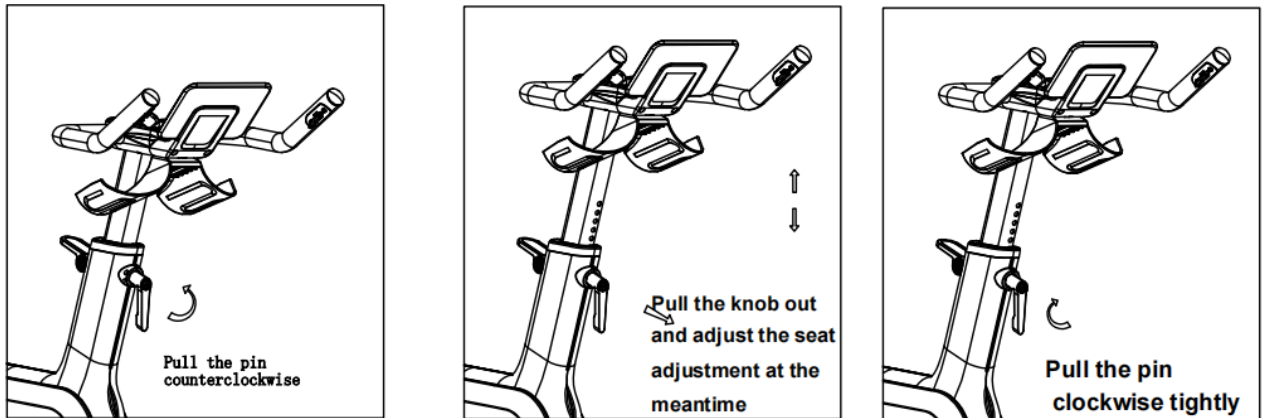

***Note:** When adjusting the instrument tube, do not exceed the "STOP" mark on the instrument tube.

10. Adjust the cushion up and down

Adjust the height of the cushion pipe up and down, rotate the knob against the clockwise 2-3 times, then pull the handle out with one hand, and move the cushion up and down with the other hand, you can adjust the comfortable height suitable for your movement up and down. After fixing it. then lock it clockwise Pull pin.

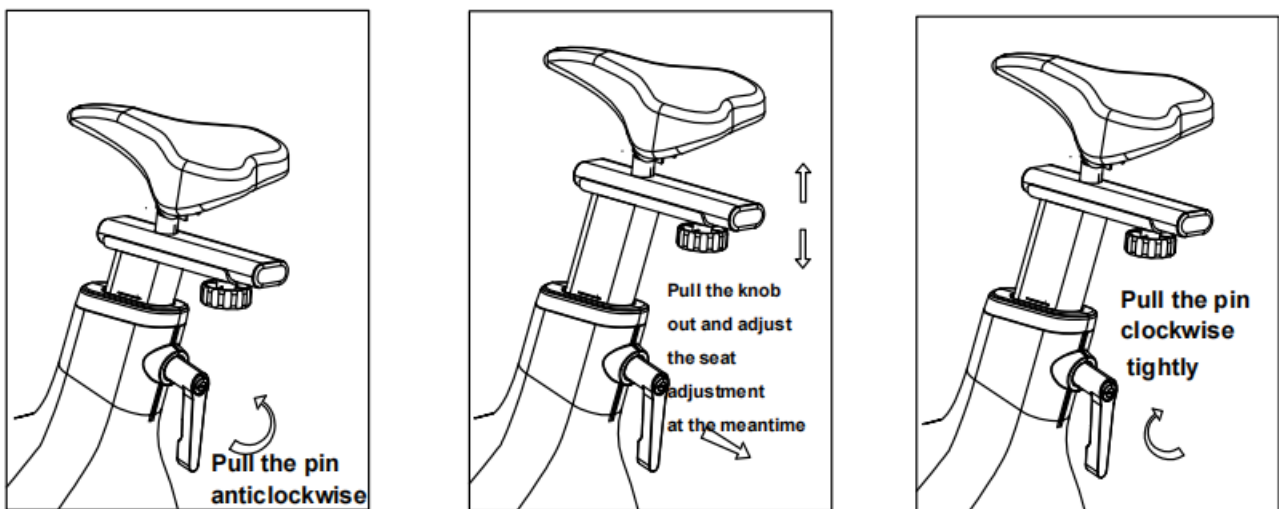

*** Note:** Do not exceed the "STOP" mark on the cushion tube when adjusting the cushion tube.

Instructions of the electronic watch

1 . The electronic balance sheet mainly displays the instructions:



Show full view

- 1 . Outer ring with 24 effect lights
- 2 . Display "heart rate" in "bpm"
- 3 . Display the "LEVEL" resistance level
- 4 . Display the motion data, Speed, Time, Distance, Calories
- 5 . Display the Bluetooth connection status



Rotation mode

- 1 . Each data was rotated and switched every 3s
- 2 . Small window numbers display the "LEVEL" resistance level
- 3 . Main window digital rotation "speed" time "distance" calories"
- 4 . The Bluetooth light indicates the Bluetooth connection status. The connection is on and not connected extinct
- 5 . The motion outer ring is all lit by default



Lock mode

- 1 . Short press knob can switch display mode, lock in what you need to see the data
- 2 . "The main window can lock the display data "speed" time distance road"
- 3 . Small window numbers display the "LEVEL" resistance level
- 4 . The motion outer ring is all lit by default

Instructions of the electronic watch

2.Main operation instructions of electronic sheet:



Sleep wake up

- 1 .Dormant state, displayed off
- 2 .Short-press the knob or detect the cycling movement, and the knob wakes up

Press the button

- 1 .No operation or movement, and the knob becomes dormant after 3 minutes
- 2 .Dormant state, short press the knob to wake up the device
- 3 . Wake-up state, the short press knob can enter the movement state
- 4 .Movement state, the short press knob can switch the display mode
- 5 .Movement state, long press the knob "2S" can reset the data into the wake-up state when pressing the knob, a buzzer indicates it



Rotation button







- 1 .Rotate clockwise to increase the resistance
- 2 . Rotate counterclockwise to reduce the resistance
- 3 . Turn the knob , there are buzzer tips
- 4 .Movement state, the short press knob can switch the display mode
- 5 .Movement state, long press the knob "2s" can reset the data into the wake-up state



When pressing the knob, a buzzer indicates it

Instructions of the electronic watch

3. The data display of the electronic watch :

No.	Item	Display window	Instruction
1	Resistance level		1-32
2	SCAN		Display: Representative data in the rotation mode Not displayed: represents data in locked mode
3	Speed		0.0 ~ 9999 km/h
4	Time		00:00 ~ 99:59
5	Distance		0.0 ~ 9999 km
6	Calories		0.0 ~ 9999 kilocalorie
7	Bluetooth icon		Display: The Bluetooth is connected Not display: Bluetooth not connected

Download the APP instructions

- 1) Scan the QR code below and choose to download the YIFITAPP according to your mobile phone system type
- 2) Download and install and complete the registration and login
- 3) Follow the APP prompt to guide the connected device to use



Start guide

Stretch motion recommendation ,

The right chart lists the correct posture for several basic stretching movements. Do stretching movements slowly, not suddenly.

1.Touch your toes lightly to stretch them
When standing, the knees are slightly curved, and the hips above are slowly bent forward. Relax your back and shoulders as your hands touch your toes down as gently as possible. Hold up for 15 seconds before relax. Repeat the above action for three times. Extension tended ligaments, medial knee and back.

2.Start with stretching
Sit down with your leg forward. Hold the sole of the other foot down to the body and place it on the inner thigh of the extended leg. Touch your toes as gently as possible. Relax for 15 seconds and repeat three times on each leg. Site tended extension: ligament, low back and groin.

3.Shank / ankle extension exercises
Stand back and forth on your legs, lean forward, and put your hands against the wall. The back leg is pushed straight, with the feet flat on the floor. The front legs are bent and your front hips move forward to the wall. Hold up for 15 seconds before relax. Each leg moves three times to further extend the Achilles tendon, can bend the hind legs at the same time, extension areas: calf, Achilles tendon and ankle.

4.Trenriceps extension exercises
One hand on the wall in balance, the other hand holding the foot back. Keep your heels as close to possible to your hips. Hold up for 15 seconds before relax. Repeat the movements for each leg three times. Stretch area: quadriceps and hip muscles.

5.Indial thigh extension
Use the inner thigh stretches in a sitting position, with the sole of the foot opposite and the knee valgus. Pull your feet as close to the groin as possible. Hold up for 15 seconds before relax. Repeat the above action for three times. Stretch area: quadriceps and hip muscles.

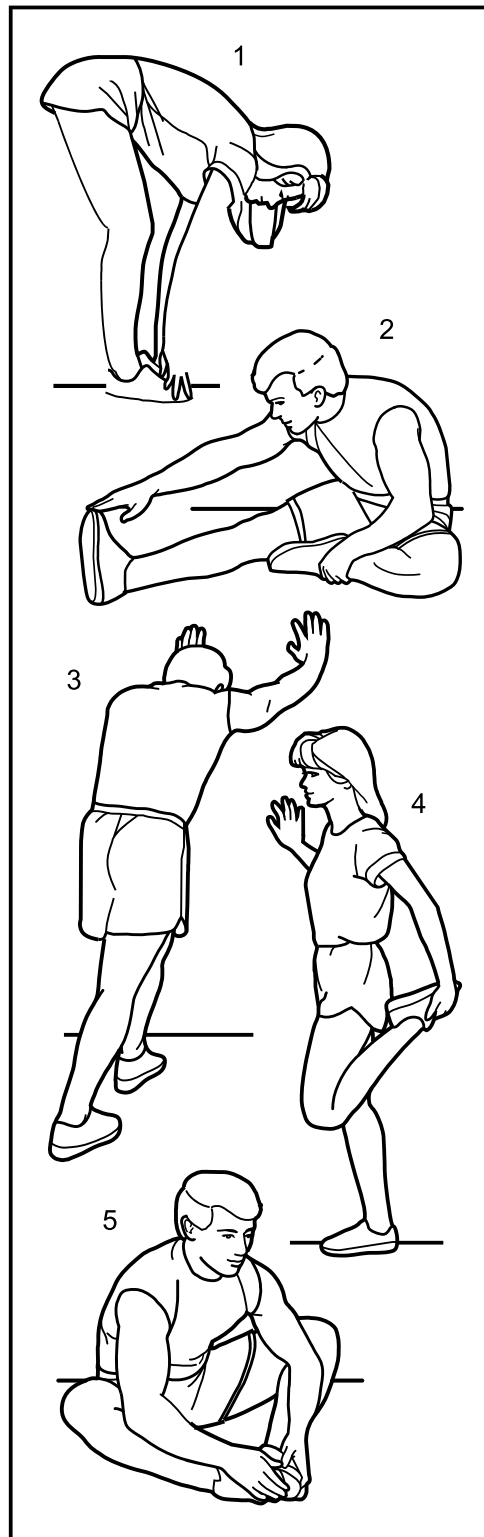

Start guide

Two, How to improve the effect of exercise

Like muscle exercise, aerobic exercise requires more blood flow and a higher heart rate, which improving the function of the cardiovascular system. Heart rate is generally judged by your pulse reading, your pulse is safe and effective, between the maximum heart rate of 87 % to 72% is called the training target area, training target should be gradually improved by making a training plan, at least 3-4 times a week, 15-20 minutes

Warning: Do not try to exercise beyond the target heart rate, must gradually, if a history, under the guidance of a doctor; people over 35-40 years without normal training, we advise you not to pass the doctor's warning. You must remember a few minutes of warm-up and cooling time (Figure B below)

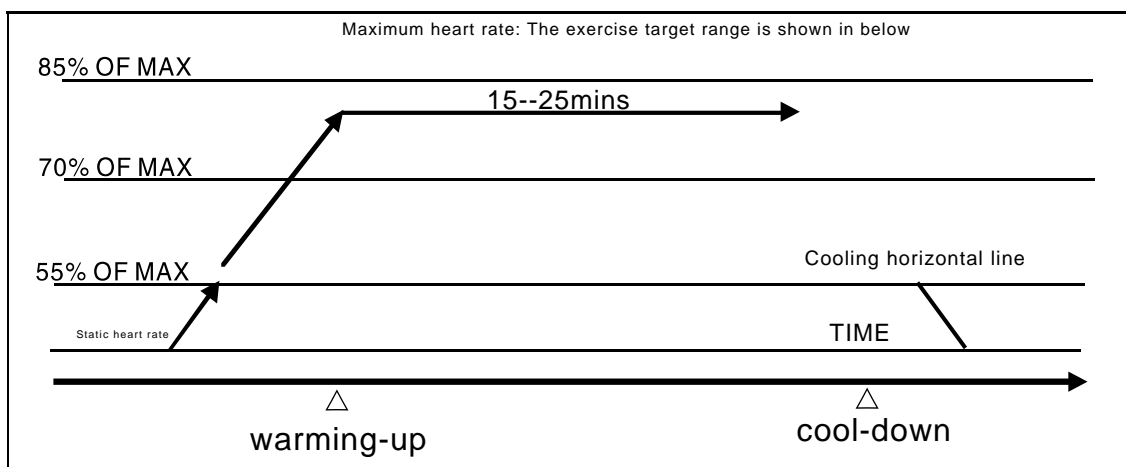

Figure B

Three, methods for maintenance and troubleshooting

1. Regularly check whether the bolts and nuts of each part are fastened, whether the adjustment knob is locked, whether the rotating part is flexible, and whether there are worn or damaged parts. The condition of these parts is good, and the safety of the equipment is guaranteed;
2. After the worn or damaged parts are found, they should be immediately removed or sent to the maintenance center for repair. It can be used after repair.
3. Keep the equipment clean, but do not wipe with acidic, alkaline or organic solution.
4. Fault and troubleshooting method:

hitch	Reason	The exclusion	Remark
The rack is uneven	1. The ground is uneven or has debris. 2. The frame is not leveled when the base is assembled	1. Remove debris. 2. Release the connecting bolt of the frame and level the base before leveling the bolts. 3. Adjust the rear bottom tube eccentric foot sleeve	The user
The hand is not stable	The thread loose	Tighten the bolt	The user
The ating parts have a sound	Gap dysregulation	Turn on the cover adjustment	Service center
Turn weakly	1. Increase of magnetic resistance gap 2The fine-tuner is damaged	1. Open the cover for adjustment 2. Replace 3. Open the cover for adjustment	Service center